

## CASE STUDY

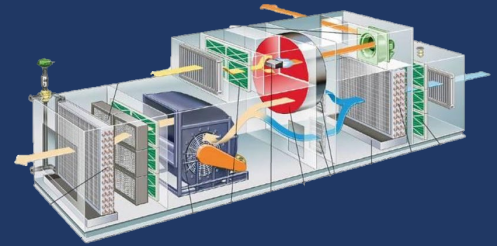

Utilize desiccant dehumidification to condition product conveying air from main powder collection cyclones to packaging cyclone.

**Industry:** Food & Beverage  
**Application:** Desiccant dehumidification for powder conveying  
**End User:** Global leader in development of taste & nutrition solutions for food, beverage & pharmaceutical markets  
**Product:** Munters ICA - Desiccant Dehumidification Unit

### BACKGROUND



GLM Hydro LLC is a North American based company with over 50 years of combined experience in evaporation, crystallization and drying technology for the food, dairy, pharmaceutical and chemical industries.



We are **Industrial Conditioning Equipment (ICE)**, a manufacturer's representative for some of the highest quality industrial air treatment equipment manufactured in the industry.



**Munters Corporation** is a global leader in the manufacturing of industrial desiccant dehumidification systems down to -90F dewpoint. Munters DH systems are used in over 20 major industries including food, pharmaceutical and battery manufacturing.

### The Challenge:

Powder product is transported from the high temp main powder collection cyclones to the packaging cyclone. This product must be conditioned year-round with low temperature and low dewpoint air to prevent condensation from forming in two locations:

- Powder transport lines
- Bottom of spray chamber when transport air is introduced into main product ductwork

### The Solution:

GLM Hydro LLC chose Munters Corporation to provide the dehumidification equipment for the powder transport. The Munters ICA desiccant system designed to treat OA was coupled with an air prep unit to provide year-round optimal conditions.

### The Results:

To date, the Munters unit has exceeded performance expectations, achieving conditions below design. As a result, the chances of lumping & sticking of the product in the packaging during storage & transport is greatly reduced.

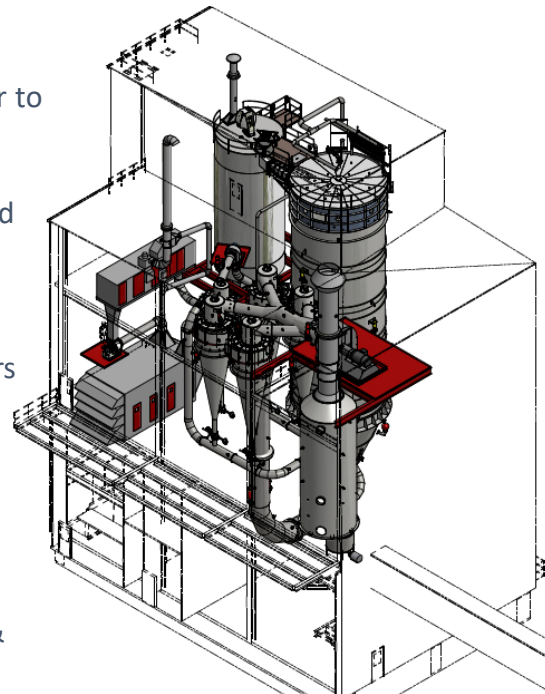

Talk with an expert today!



**Industrial Conditioning Equipment, LLC**

☎ 609-655-8980 | ✉ info@icenj.com  
www.icenj.com

**GLM Hydro, LLC**

☎ 732-800-0199 | ✉ sales@glmhydro.com  
www.GLMHydro.com

# MUNTERS DESICCANT DEHUMIDIFICATION SOLUTION

Munters ICA desiccant dehumidification system

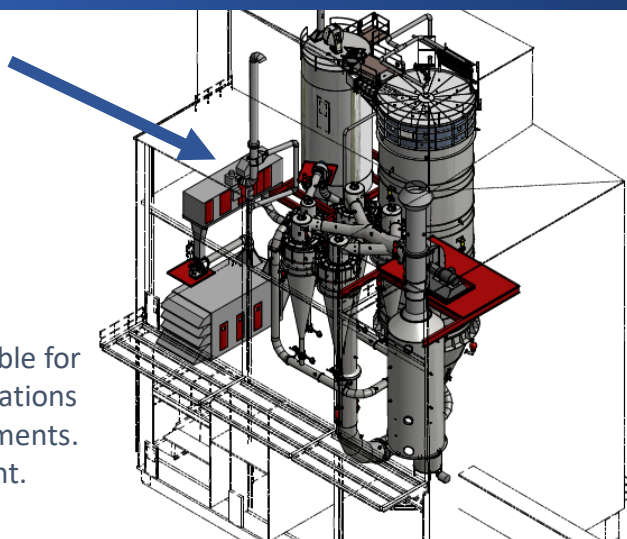

The ICA (Integrated Custom Air Handler) is especially suitable for food processing and pharmaceutical manufacturing applications that operate under strict FDA and GMP sanitation requirements. Units can be customized to meet most any requirement.

**Without the use of desiccant dehumidification, condensation is likely to occur within your system. Condensation can cause a myriad of issues, including, but not limited to:**

- ✓ Reduced production, particularly in the summer
- ✓ Lumping & sticking of the product during storage & transport
- ✓ Damage to equipment & machines
- ✓ Degradation of product quality

### Munters ICA Features:

- Innovative Double Wall Construction with 22-gauge stainless steel interior & exterior walls
- Superior No-Through Metal Design (Prevents Sweating)
- Triple-sloped floor drains integral to floor panel for wash down & sanitation.
- NEMA 4X stainless steel control enclosure

### Munters Desiccant Rotor Principle

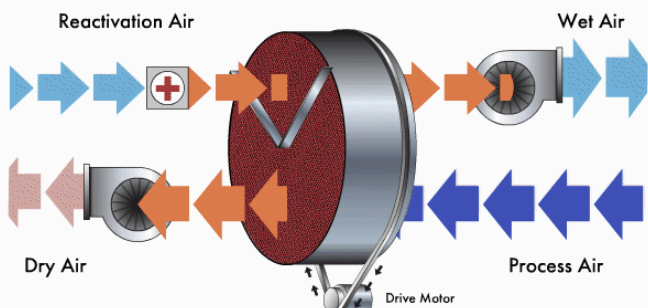

### INSTALLED MUNTERS UNIT



609-655-8980

1258 S River Rd  
Cranbury, NJ 08512

info@icenj.com

www.icenj.com