

CASE STUDY

Custom outside air filter box for the inlet to a Munters indirect gas heat exchanger for a spray dryer.

Industry: Chemical Manufacturing

Application: Air Purifying requirement related to a product substrate

End User: Global additives and specialty ingredients company

Product: Griffin Filter Technologies Custom Air Prep Filter Box

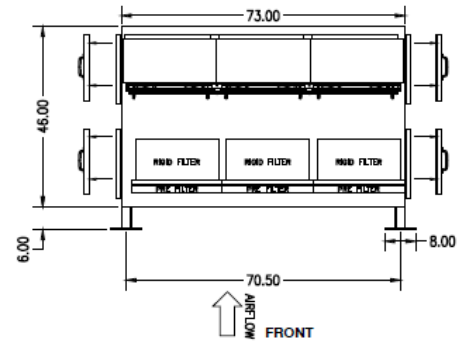

BACKGROUND



GLM Hydro LLC is a North American based company with over 50 years of combined experience in evaporation, crystallization and drying technology for the food, dairy, pharmaceutical and chemical industries.



We are **Industrial Conditioning Equipment (ICE)**, a manufacturer's representative for some of the highest quality industrial air treatment equipment manufactured in the industry.



Griffin Filters is a leading manufacturer of dust collection systems for over 50 years. Standard and custom models to match a wide range of application needs, from solids processing to product recovery and air pollution control.

The Challenge:

GLM Hydro was tasked with retrofitting an existing direct-fired gas spray dryer with a Munters indirect gas heat exchanger. The existing filter box could not be configured to match the new heater and air prep units, therefore a new, customer air prep filter box was required. GLM Hydro called on ICE to assist.

The Solution:

A 10,500 CFM, three-stage, SST custom filter box by Griffin Filter Technologies, complete with Merv 8, Activated Carbon & HEPA filtration. This 14-gauge, all-welded, vertical filter box was designed to withstand coastal ambient conditions and included custom transitions & passivation of all welds.

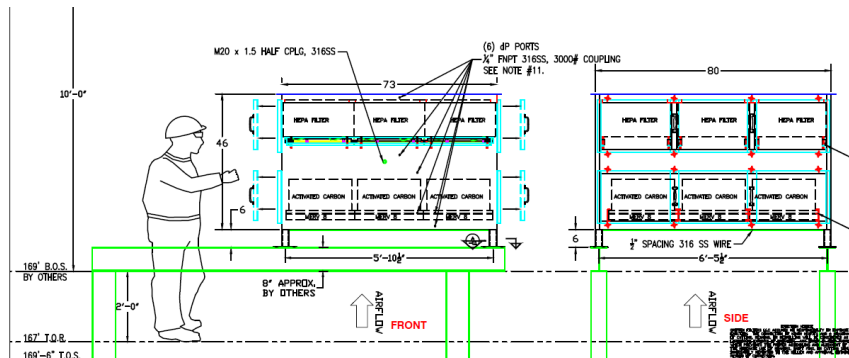

Talk with an expert today!

Industrial Conditioning Equipment, LLC

☎ 732-524-7544 | ✉ info@icenj.com

www.icenj.com

GLM Hydro, LLC

☎ 732-800-0199 | ✉ sales@glmhydro.com

www.GLMHydro.com